

# ROVV<sup>®</sup>

## Double- offset Metal Sealing Butterfly Valve

PRODUCT  
CATALOGUE



ROVV<sup>®</sup>

# EQUIPMENT



## COMPANY INTRODUCTION

SHANGHAI ROGERS VALVE CO. LTD is one of the leading companies specializing in the R&D, design and manufacture of a full range of INDUSTRIAL VALVES made from premium materials, including **Ball valves, Check valves, Butterfly valves, Gate valves, Globe valves, Control valves and a wide range of related accessories.** These products find extensive applications in industries such as petrochemicals, power generation, pharmaceuticals, firefighting and heating, municipal construction, natural gas, water supply, and drainage. The company provides customers with one-stop valve solutions.

Customized design to meet specific needs is a core strength of the company. After years of cultivation, the company has developed strong capabilities in customized design and manufacturing. Extensive research and simulation of operating conditions are conducted to meet the different requirements of valve applications in special scenarios. The products are characterized by high reliability, long service life, easy maintenance, and excellent performance, meeting customer demands for **safety, environmental protection, economy, and stability.** As a result, the company has gained consistent praise and trust from its customers.

While rooted in China, the company has a global outlook. In the context of global competition, ROWV actively participates in domestic and international markets. **By enhancing its technical capabilities and service quality, the company aims to expand its market share and establish the reputation of Chinese valve brands.**



The company focuses on the combination of Chinese craftsmanship and lean quality. **Internally, ROWV has a professional R&D and production team comprising over 80 high and intermediate-level technical personnel. Significant investment has been made to introduce automation equipment.** Externally, the company has adopted advanced manufacturing processes, professional technical experts, and modern management concepts from ROWV Machinery Manufacturing in the United States. By integrating Chinese craftsmanship with an international perspective, the company achieves a highly flexible, composite, and lean manufacturing process, as well as a networked, information-based, and intelligent manufacturing and management process, ensuring product consistency, stability, and lean quality.

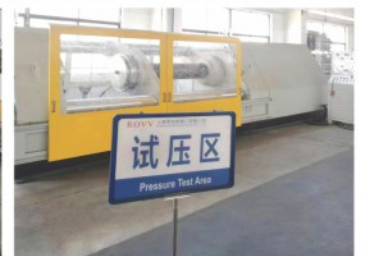

Provide customers with one-stop valve solutions.

# CERTIFICATES

Focusing on expertise in a single field, the company has achieved notable recognition. ROVV has obtained certifications such as **ISO 9001 Quality Management System, ISO 14001 Environmental Management System, ISO 45001 Occupational Health and Safety Management System, TS National Special Equipment Production License, API 607 Fire Certification, Russia EAC Certification, SIL Valve Safety Level Certificate, and so on.** The company has also received honors such as AAA Credit Enterprise and National Product and Service Quality Integrity Brand.



TS National Special Equipment Production License    ISO 9001 Quality Management System    ISO 14001 Environmental Management System    ISO 45001 Occupational Health and Safety Management System





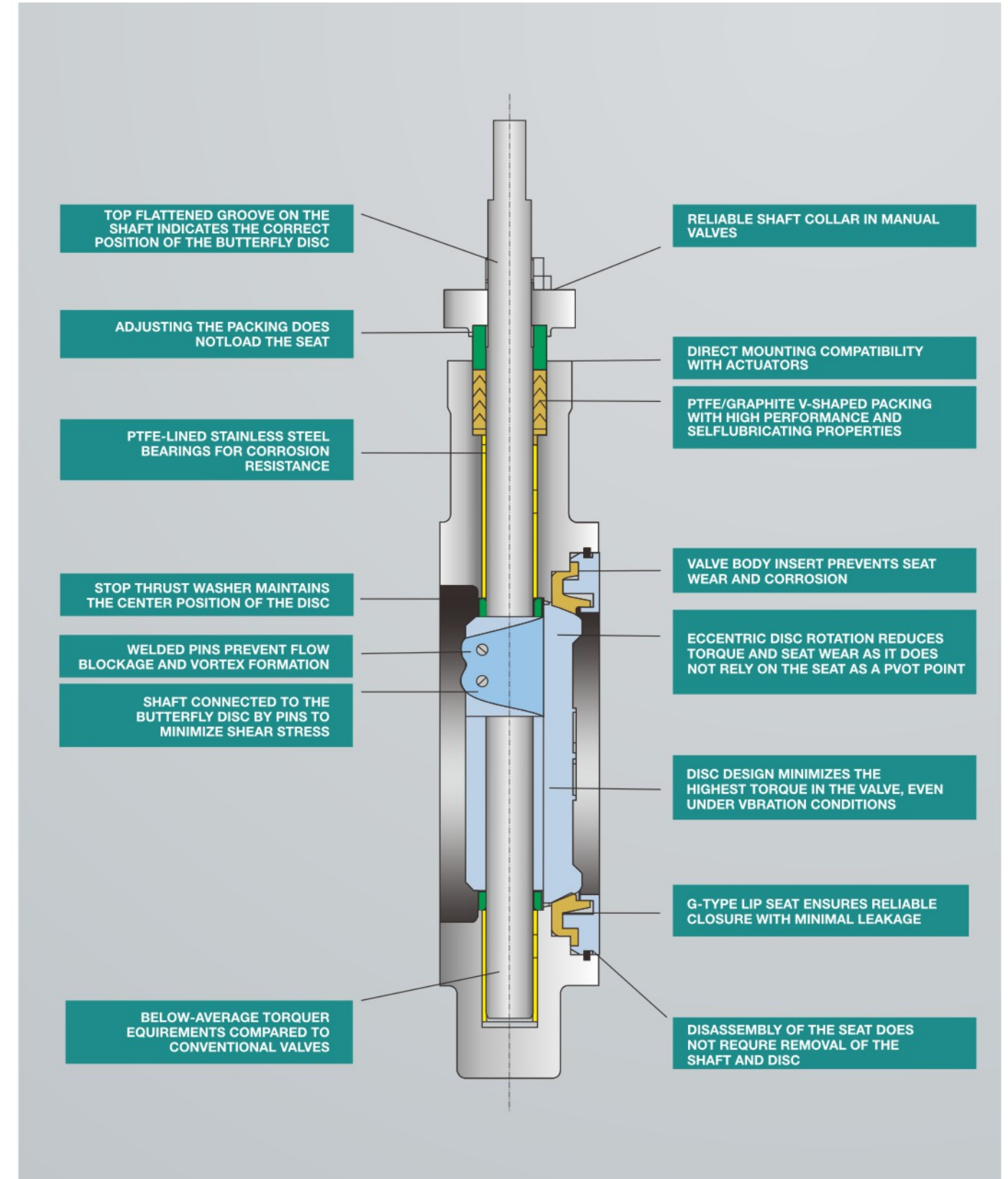

SIL Valve Safety Level Certificate    API 607 Fire Certification    ISO 15848-1 Qualificate Certificate    Russia EAC Certification

# UNLEASH THE POWER OF HIGH-PERFORMANCE BUTTERFLY VALVES: EXPLORING THE MARVELS OF THEIR STRUCTURAL FEATURES



# PRODUCTS CATALOGUE

<b>DBGY</b>				
<b>Name</b>	Double- offset metal sealing <b>WAFER handle Butterfly Valve</b>	Double- offset metal sealing <b>WAFER HIGH PLATFORM Butterfly Valve</b>	Double- offset metal sealing <b>LUG Butterfly Valve</b>	Double- offset metal sealing <b>FLANGED Butterfly Valve</b>
<b>Characters</b>	Double offset valve as wafer/ LUG/ Flanged type butterfly valve for high pressure and temperature loads			
<b>Size</b>	DN50~DN600			
<b>Differential Pressure</b>	PN 16/16/25/40 / ANSI Class 150/300/API			
<b>Tempreture range</b>	Minus 196°C to 425° C			
<b>Body Material</b>	Carbon steel, Stainless steel, Monel, Ha's alloy, duplex stainless steel			
<b>Seal Material</b>	INCONEL, STL 6			
<b>Design Standard</b>	API609/DIN EN 12266 P10 P11 P12 F20			
<b>Actuators</b>	Pneumatic/electric/Worm/wheel/Lever			
<b>General Applications</b>	Steam in high temperature			
	Metallurgy and mining			
	Chemical and petrochemical industry			
	Air separation plant VPSA			
	Desailnator LNG			
	Salt industry			

# MAIN PRODUCTS' FEATURES

## METAL SEAT RING

The seat ring's special form provides excellent spring characteristics. Constructed with 1.4571 nitrated material, it offers high-temperature resistance and can maintain tightness up to +425°C, in accordance with EN12266 standards and with a leakage rate of B.

## METALLIC LIP SEAL STRUCTURE DESIGN LIP SEAL

When closed, the METAL lip seal (A) flexes and tightly seals against the outer edge of the spherical disc (B), ensuring reliable sealing. The valve body (C) and gasket (D) secure the sealing seat and isolate the sealing surface from the media, preventing corrosion on the sealing surface. The design offers excellent spring characteristics due to its special shape. The seat, made of inconel material, provides high temperature resistance, with sealing capability up to +400°C, complying with EN12266 standard, leakage rate being B.

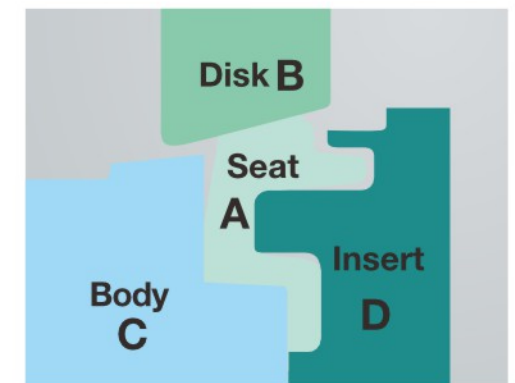

The double offset design of the valve ensures reliable and nearly wear-free shut-off. With the dual displacement of the pivot, the valve disc lifts off the seat at the start of the opening motion, relieving heavy pressure load around the entire circumference of the seat. The frictionless 90° rotation operates with reduced torques, enabling an exceptionally long service life, even under high switching frequencies. The recommended pressure direction (indicated by an arrow mark on the body) guarantees complete tightness.

Furthermore, the active pressure, or differential pressure, of the medium enhances the sealing function by exerting pressure on the seat ring against the sealing surface of the disc. The insert ring and the body effectively safeguard the flexible seat ring against adverse flow influences.

## DOUBLE OFFSET DESIGN

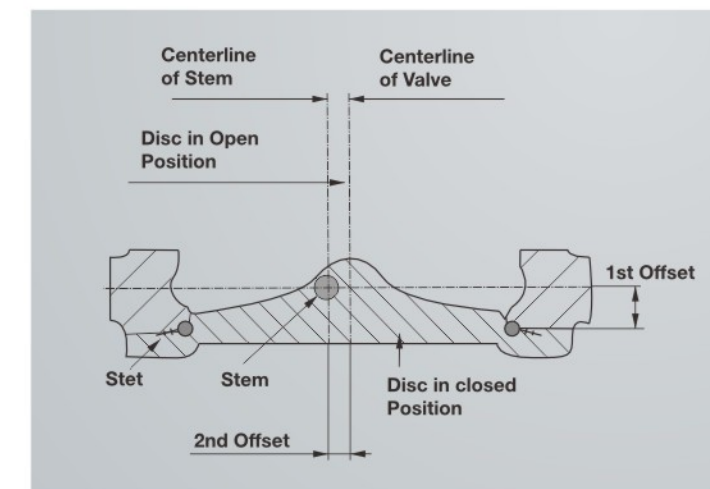

WHEN THE VALVE OPENS, THE ECCENTRIC DISC QUICKLY MOVES AWAY FROM THE SEAT SEALING SURFACE, RESULTING IN ONLY SHORT CONTACT BETWEEN THE DISC AND THE SEAT SEALING SURFACE. THIS DESIGN PROLONGS THE LIFESPAN OF THE VALVE.

# PRESSURE AND TEMPERATURE RANGE DIAGRAM

Nominal size	Nominal pressure	max. operating pressure
DN 50 - DN 300	PN 10/16/25/40 ANSI 150/300	25 bar or 40 bar
DN 350 - DN 500	PN 10/16/25 ANSI 150	16 bar
> DN 600	PN 10/16 ANSI 150	10 bar

The maximum operating pressure depends on the operating temperature.

## Control range

20 ° – 60 ° opening angle

## Vacuum-tight

up to 1 mbar (a)

## Flange surfaces

according to DIN EN 1092-1 form B1

The pressure and temperature range diagram shows the application limits of the different seat ring materials. These limits apply to the intended use. Process variables and characteristics of the medium can influence the values of the diagram. Temperatures below -50°C upon request.

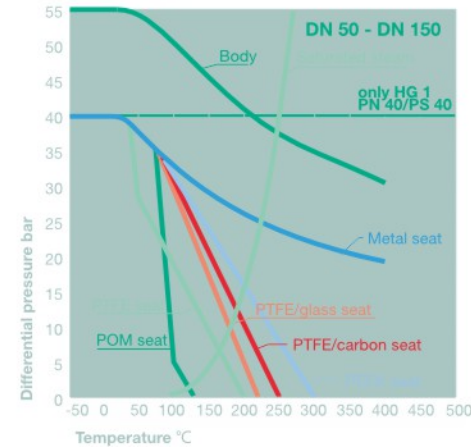
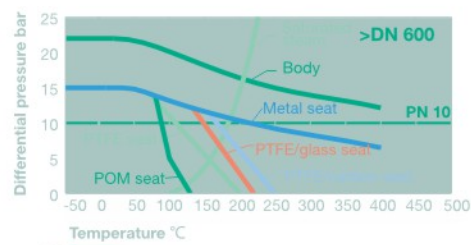
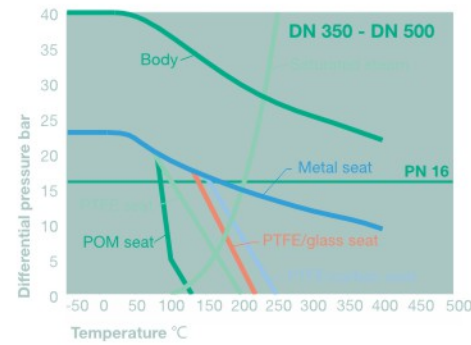
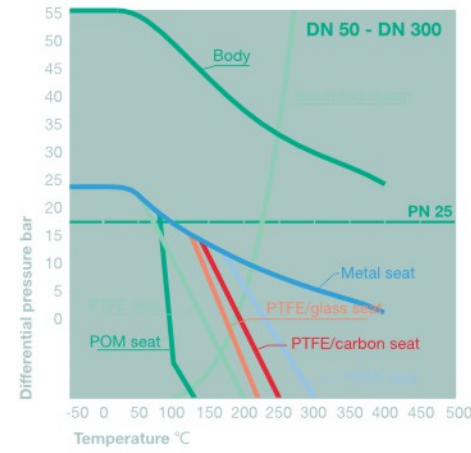

# TORQUE TABLE

Size		Class 150	Class 300
		Metal sealing	
DN	NPS	N-M	N-M
65	2.5	74	250
80	3	93	520
100	4	162	947
125	5	260	1154
150	6	508	1908
200	8	720	2830
250	10	1125	4950
300	12	1540	5700
350	14	2560	8740
400	16	3304	11650
450	18	3971	20175
500	20	5192	25415
600	24	8546	36880

HIGH PERFORMANCE BUTTERFLY VALVE MODEL										
1	2	3	4	5	6	7	8	9	10	11
TYPE	DESIGN	METAL SEALING	CONNECTION	PRESSURE	OPERATION	BODY	STEM	DISC	SEAT	SIZE
DB-DOUBLE OFFSET BUTTERFLY	G/A/D/J	Y-METAL	8 -WAFER 5-LUG 4-FLANGED	PN10 PN16 PN25 PN40 150LB 300LB	M-MANUAL G-GEAR O-BRAE SHAFT	20-WCB	17 -17-4PH	36-CF8M	IN-INCONEL ST-STL6	2"-60"

# WAFER TYPE BUTTERFLY VALVE

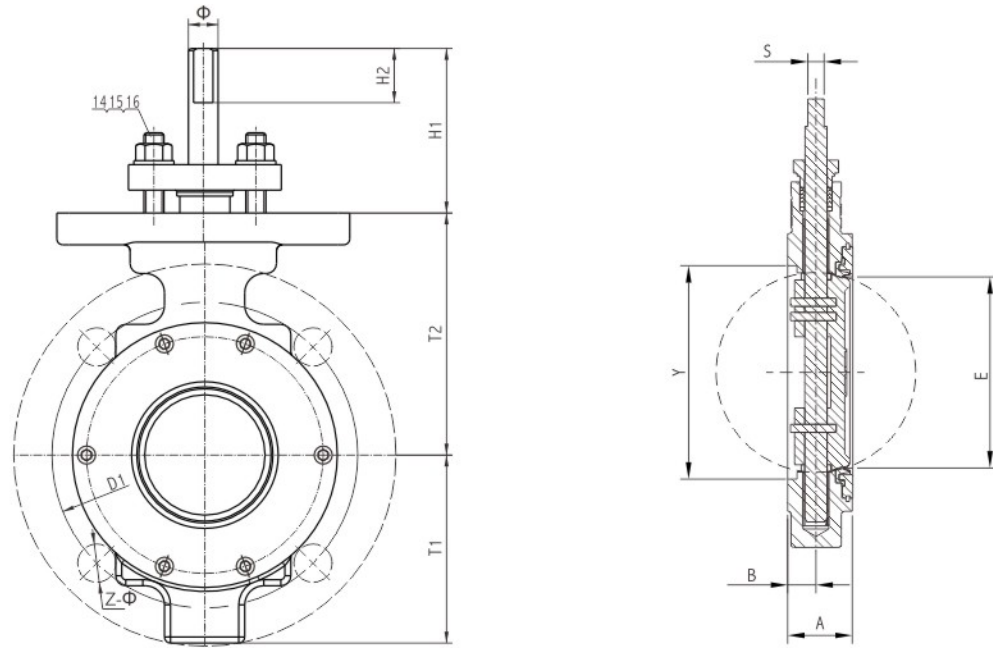

## 2" ~ 12" (DN50~300) Size & Weight

Size		American standard flange 150Lb		National standard flange GB PN16		Japanese standard flange JIS 10K	
NPS	DN	D	N-Φ	D	N-Φ	D	N-Φ
2"	50	Φ120.7	4-Φ19	Φ125	4-Φ18	Φ120	4-Φ19
2.5"	65	Φ139.7	4-Φ19	Φ145	8-Φ18	Φ140	4-Φ19
3"	80	Φ152.4	4-Φ19	Φ160	8-Φ18	Φ150	8-Φ19
4"	100	Φ190.5	8-Φ19	Φ180	8-Φ18	Φ175	8-Φ19
5"	125	Φ215.9	8-Φ22	Φ210	8-Φ18	Φ210	8-Φ23
6"	150	Φ241.3	8-Φ22	Φ240	8-Φ23	Φ240	8-Φ23
8"	200	Φ298.5	8-Φ22	Φ295	12-Φ23	Φ290	12-Φ23
10"	250	Φ362	12-Φ25	Φ355	12-Φ25	Φ355	12-Φ25
12"	300	Φ431.8	12-Φ25	Φ410	12-Φ25	Φ400	16-Φ25

Size (DN)	Approximate size (mm)										Weight (kg)
	A	B	C	E	G	K	P	S	X	Y*	
50	43	20	96	38	124.3	80	186.3	7	10	50	3.2
65	49	22	119	59	194	111	275	11.2	14.8	75	5
80	49	22	132	73	203	121	297	11.2	14.8	89	6
100	54	24	157	95	216	140	326	11.2	14.8	115	8
125	56	26	186	111	217	135	345	11.2	14.8	141	12
150	57	24	216	142	235	152	378	14	18	159	13
200	64	28	274	188	270	187	441	15.9	21.9	210	20
250	72	31	330	236	329	232	530.6	20.6	28	254	35
300	81	34	386	282	357	260	595.5	23.8	33.3	305	51

The above data only for reference, and the detailed parameters in the sample drawing when you make an inquiry.

# WAFER TYPE BUTTERFLY VALVE

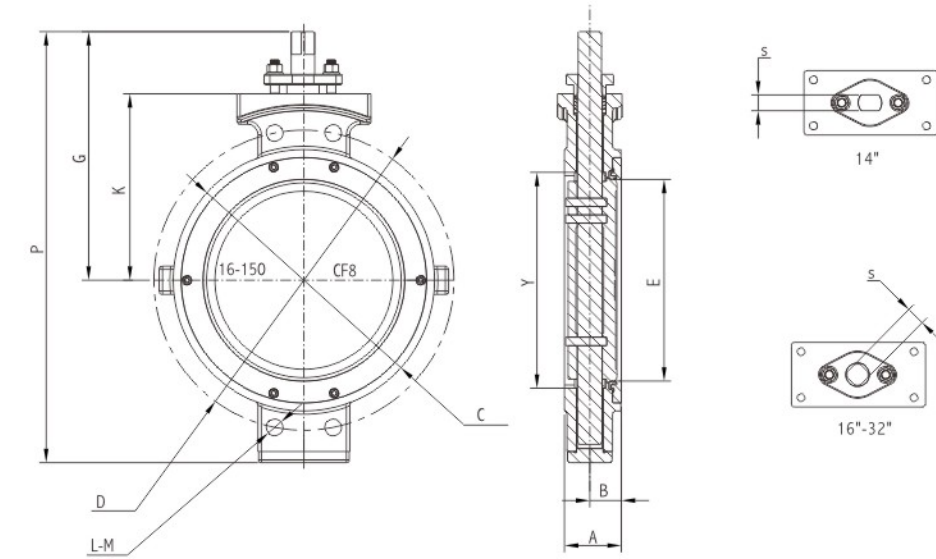

L = Number of Valve Body Bolt Holes  
M = Valve Body Bolt Specification downstream shaft, fire-resistant seat

## 14" ~ 40" (DN350~800) Size & Weight

Size		American standard flange 150Lb			National standard flange GB Pn16			Japanese standard flange JIS 10K		
NPS	DN	D	N-Φ	L-M	D	N-Φ	L-M	D	N-Φ	L-M
14"	350	Φ476.3	12-Φ30	-	Φ470	16-Φ26	-	Φ445	16-Φ25	-
16"	400	Φ539.8	16-Φ30	4-Φ30	Φ525	16-Φ30	4-Φ30	Φ510	16-Φ27	4-Φ27
18"	450	Φ577.9	16-Φ33	4-Φ33	Φ585	20-Φ30	4-M27	Φ565	20-Φ27	4-M24
20"	500	Φ635	20-Φ33	4-M30	Φ650	20-Φ33	4-M30	Φ620	20-Φ27	4-M24
24"	600	Φ749.3	20-Φ35	4-M33	Φ770	20-Φ36	4-M33	Φ730	24-Φ33	4-M30
28"	700	Φ863.6	28-Φ35	4-M33	Φ840	24-Φ36	4-M33	Φ840	24-Φ33	4-M30
30"	750	Φ914.4	28-Φ35	4-M33	-	-	-	Φ900	24-Φ33	4-M30
32"	800	Φ977.9	28-Φ41	4-M39	Φ950	24-Φ39	4-M36	Φ950	28-Φ33	4-M30
36"	900	Φ1085.8	32-Φ42	4-M39	Φ1050	28-Φ39	4-M36	Φ1050	28-Φ33	4-M30
40"	1000	Φ1200.2	36-Φ42	4-M39	Φ1170	28-Φ42	4-M39	Φ1160	28-Φ39	4-M36

Size (DN)	Approximate size (mm)											Weight (kg)	
	A	B	C	D	E	G	K	M	L	P	S		Y
350	92	52	416	Φ476.3	314	415	315	Φ29	-	710	28.7	343	66
400	102	56	474	Φ539.8	363	446	335	Φ30	4	767	33.5	388	99
450	114	67	538	Φ577.9	414	466	355	Φ33	4	812	41.4	445	130
500	127	67	584	Φ635	456	482	377	M30	4	879	41.4	495	170
600	154	76	693	Φ749.3	549	620	490	M33	4	1094	51	597	296
700	165	87	800	Φ863.6	682	687	530	M33	4	1216	60	713	340
750	190	87	900	Φ914.4	702	727	570	M39	4	1285	60	740	-
800	190	87	905	Φ977.9	753	722	565	M39	4	1305	60	800	465
900	203	102	1022	Φ1086	885	817	660	M39	4	1456	70	905	656
1000	216	101	1124	Φ1200.2	972	893	713	M39	4	1580	80	1005	-

The above data only for reference, and the detailed parameters in the sample drawing when you make an inquiry.

# WAFER TYPE BUTTERFLY VALVE

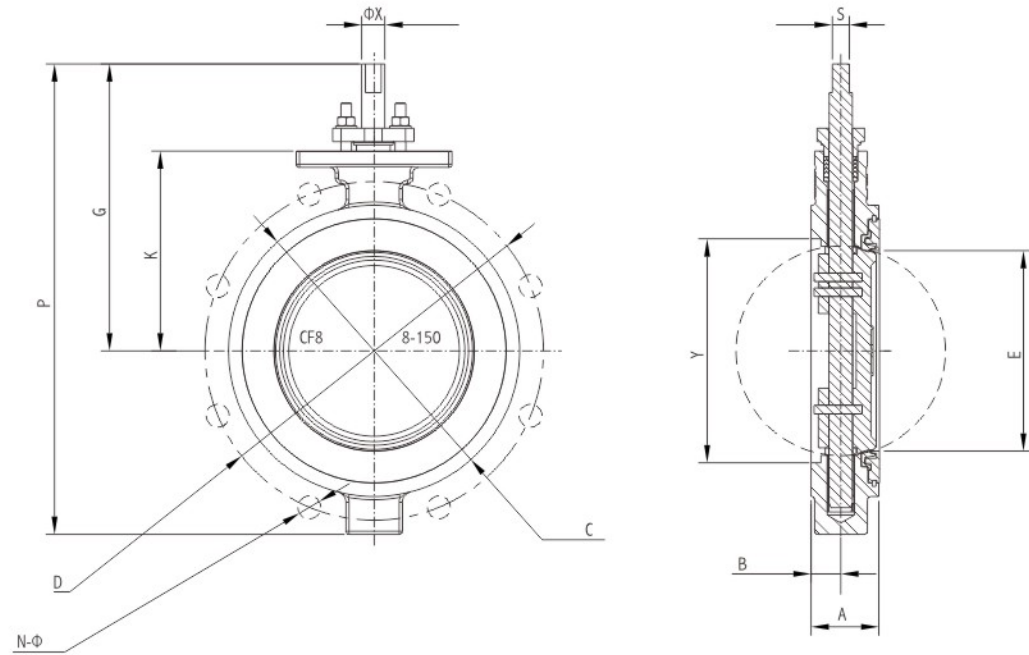

## 2" ~ 12" (DN80 ~ 300) Size & Weight

Size		American standard flange 300Lb			National standard flange GB PN40			Japanese standard flange JIS 10K		
NPS	DN	D	N-Φ	L-M	D	N-Φ	L-M	D	N-Φ	L-M
2"	50	Φ127	8-Φ19	-	Φ125	4-Φ18	-	Φ120	8-Φ19	-
2.5"	65	Φ149.2	8-Φ22	-	Φ145	8-Φ18	-	Φ140	8-Φ19	-
3"	80	Φ168.3	8-Φ22	-	Φ160	8-Φ18	-	Φ160	8-Φ23	-
4"	100	Φ200	8-Φ22	-	Φ190	8-Φ22	-	Φ185	8-Φ23	-
5"	125	Φ235	8-Φ22	-	Φ220	8-Φ26	-	Φ225	8-Φ25	-
6"	150	Φ269.9	12-Φ22	-	Φ250	8-Φ26	-	Φ260	12-Φ25	-
8"	200	Φ330.2	12-Φ25	-	Φ320	12-Φ30	-	Φ305	12-Φ25	-
10"	250	Φ387.4	16-Φ29	4-M27	Φ385	12-Φ33	4-M30	Φ380	12-Φ27	4-M24
12"	300	Φ450.8	16-Φ32	4-M30	Φ450	16-Φ33	4-M30	Φ430	16-Φ27	4-M24

Size (DN)	Approximate size (mm)													Weight (kg)
	A	B	C	D	E	G	K	M	L	P	S	X	Y	
50	43	20	96	Φ127	38	124.3	80	-	-	186.3	7	10	50	3.2
65	49	22	119	Φ149.2	59	194	111	-	-	275	11.2	14.8	75	5
80	49	22	132	Φ168.3	73	203	121	-	-	316	11.2	14.8	89	6
100	54	24	157	Φ200	95	216	140	-	-	341	11.2	14.8	115	8
125	56	26	186	Φ235	111	217	135	-	-	362	11.2	14.8	141	12
150	59	25	216	Φ269.9	142	257	175	-	-	413	15.9	21.9	159	15
200	73	34	270	Φ330.2	188	306	213	-	-	495	20.6	28	210	27
250	83	38	324	Φ387.4	236	353	254	M27	4	592	23.8	33.3	254	48
300	92	42	381	Φ450.8	282	389	283	M30	4	675	28.7	37	305	66

The above data only for reference, and the detailed parameters in the sample drawing when you make an inquiry.

# WAFER TYPE BUTTERFLY VALVE

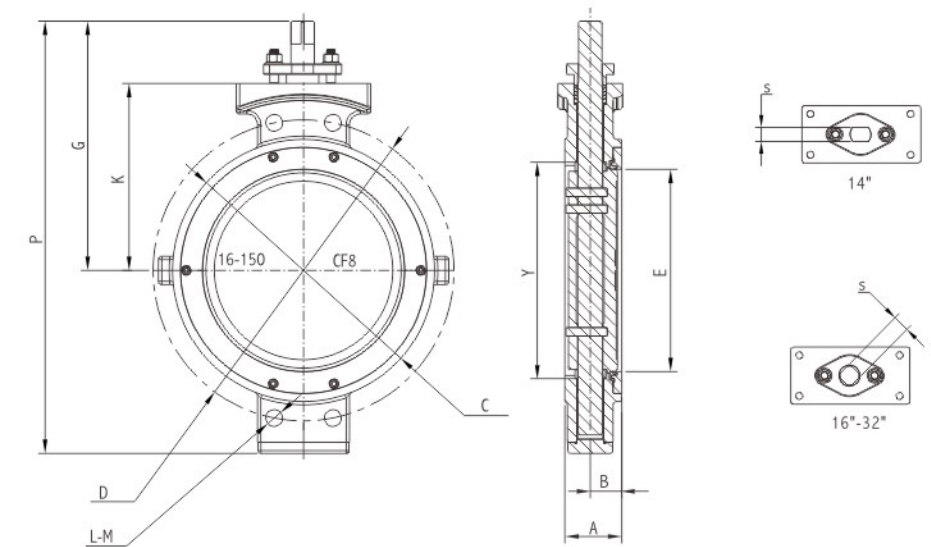

L = Number of Valve Body Bolt Holes  
M = Valve Body Bolt Specification downstream shaft, fire-resistant seat

## 14" ~ 24" (DN350 ~ 600) Size & Weight

Size		American standard flange 300Lb			National standard flange GB PN40			Japanese standard flange JIS 20K		
NPS	DN	D	N-Φ	L-M	D	N-Φ	L-M	D	N-Φ	L-M
14"	350	Φ514.4	20-Φ33	4-M30	Φ510	16-Φ36	4-M33	Φ480	16-Φ33	4-M30
16"	400	Φ571.5	20-Φ35	4-M33	Φ585	16-Φ39	4-M36	Φ540	16-Φ33	4-M30
18"	450	Φ628.6	24-Φ35	4-M33	Φ610	20-Φ39	4-M36	Φ605	20-Φ33	4-M30
20"	500	Φ685.8	24-Φ35	4-M33	Φ670	20-Φ42	4-M39	Φ660	20-Φ33	4-M30
24"	600	Φ812.8	24-Φ42	4-M39	Φ795	20-Φ48	4-M45	Φ770	24-Φ39	4-M36

Size (DN)	Approximate size (mm)													Weight (kg)
	A	B	C	D	E	G	K	M	L	P	S	X	Y	
350	118	59	413	Φ514.4	314	427	325	M30	4	738	41.4	50	337	167
400	133	62	470	Φ571.5	363	452	350	M33	4	791	41.4	50	388	195
450	149	75	533	Φ628.6	414	542	424	M33	4	955	51	64	445	324
500	162	81	584	Φ685.8	455	576	446	M33	4	1075	51	64	493	406
600	184	92	692	Φ812.8	549	646	501	M39	4	1151	60	80	578	631

The above data only for reference, and the detailed parameters in the sample drawing when you make an inquiry.

# SINGLE FLANGE BUTTERFLY VALVE

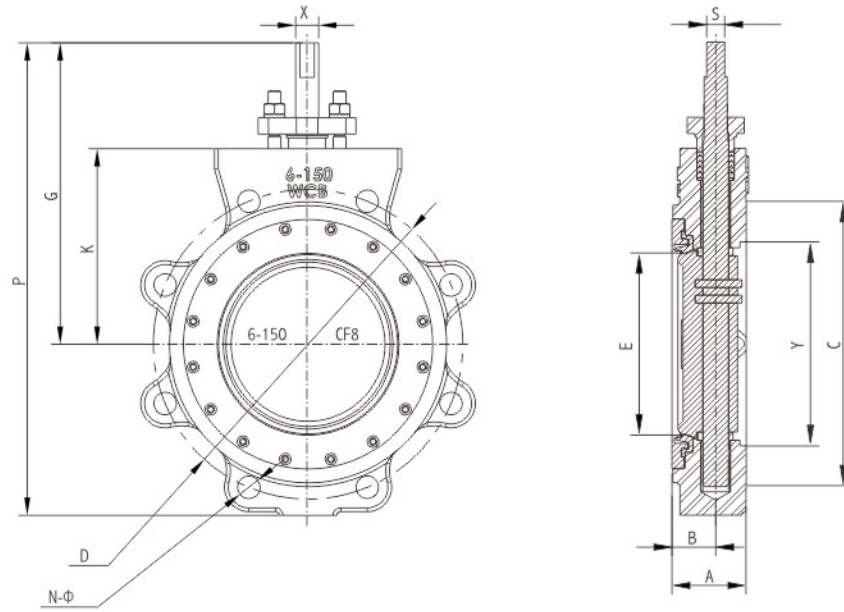

L = Number of Valve Body Bolt Holes  
M = Valve Body Bolt Specification downstream shaft, fire-resistant seat

## 2-1/2" ~ 12" (DN65~300) Size & Weight

Size		American standard flange 150Lb		National standard flange GB PN16		Japanese standard flange JIS 10K	
NPS	DN	D	N-Φ	D	N-Φ	D	N-Φ
2.5"	65	Φ139.7	4-M16	Φ145	8-M16	Φ140	4-M16
3"	80	Φ152.4	4-M16	Φ160	8-M16	Φ150	8-M16
4"	100	Φ190.5	8-M16	Φ180	8-M16	Φ175	8-M16
5"	125	Φ215.9	8-M20	Φ210	8-M16	Φ210	8-M20
6"	150	Φ241.5	8-M20	Φ240	8-M20	Φ240	8-M20
8"	200	Φ298.5	8-M20	Φ295	12-M20	Φ290	12-M20
10"	250	Φ362	12-M22	Φ355	12-M24	Φ355	12-M22
12"	300	Φ431.8	12-M24	Φ410	12-M24	Φ400	16-M22

Size (DN)	Approximate size(mm)													Weight (kg)
	A	B	C	D	E	G	K	M	L	P	S	X	Y*	
65	49	27	105	Φ139.7	59	194	111	M16	4	275	11.2	14.8	75	6.4
80	49	27	132	Φ152.4	73	203	121	M16	4	316	11.2	14.8	89	8
100	54	30	157	Φ190.5	95	216	133	M16	8	341	11.2	14.8	115	11
125	56	30	186	Φ215.9	111	217	135	M20	8	341	11.2	14.8	141	18
150	57	33	216	Φ241.5	142	235	152	M20	8	384	14	18	159	16.2
200	64	36	270	Φ298.5	188	270	187	M20	8	464	15.9	21.9	210	31
250	72	41	324	Φ362	236	325	232	M24	12	560	20.6	28	254	422
300	81	48	381	Φ431.8	282	359	260	M24	12	632	23.8	33.3	305	64.8

The above data only for reference, and the detailed parameters in the sample drawing when you make an inquiry.

# SINGLE FLANGE BUTTERFLY VALVE

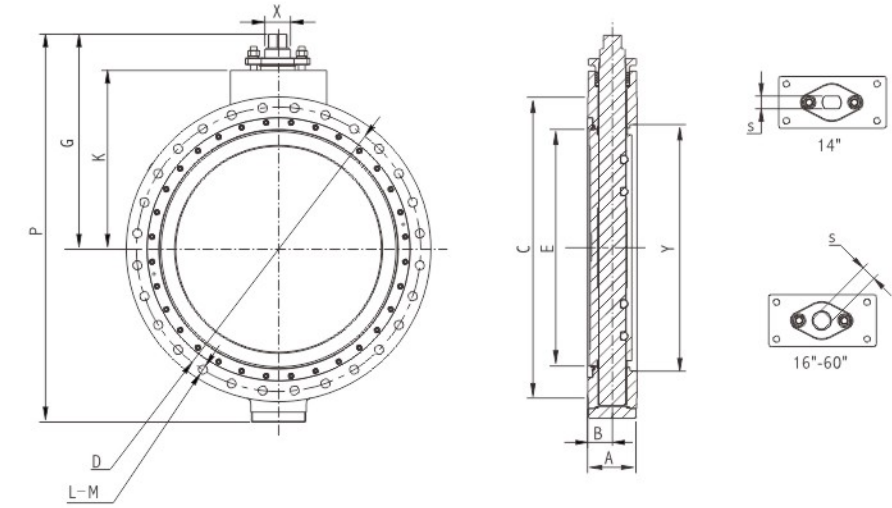

L = Number of Valve Body Bolt Holes  
M = Valve Body Bolt Specification downstream shaft, fire-resistant seat

## 14" ~ 60" (DN350~1500) Size & Weight

Size		American standard flange 150Lb		National standard flange GB PN16		Japanese standard flange JIS 10K	
NPS	DN	D	L-M	D	L-M	D	L-M
14	350	Φ476.3	12-M27	Φ470	16-M24	Φ445	16-M22
16	400	Φ539.8	16-M27	Φ525	16-M27	Φ510	16-M24
18	450	Φ577.9	16-M30	Φ585	20-M27	Φ565	20-M24
20	500	Φ635.0	20-M30	Φ650	20-M30	Φ620	20-M24
24	600	Φ749.3	20-M33	Φ770	20-M33	Φ730	24-M30
26	650	Φ806.4	24-M33	-	-	Φ780	24-M30
28	700	Φ863.6	28-M33	Φ840	24-M33	Φ840	24-M30
30	750	Φ914.4	28-M33	-	-	Φ900	24-M30
32	800	Φ977.9	28-M39	Φ950	24-M36	Φ950	28-M30
36	900	Φ1085.8	32-M39	Φ1050	28-M36	Φ1050	28-M30
42	1050	Φ1257.3	36-M39	-	-	-	-
48	1200	Φ1422.4	44-M39	Φ1390	32-M45	Φ1380	32-M36
56	1350	Φ1651.0	48-M45	-	-	Φ1540	36-M42
60	1500	Φ1759.0	52-M45	-	-	Φ1700	40-M42

Size (DN)	Approximate size(mm)													Weight (kg)
	A	B	C	D	E	G	K	M	L	P	S	X	Y*	
350	92	52	413	Φ476.3	314	394	309	M27	12	705	28.7	37	354	105
400	102	56	470	Φ539.8	363	446.4	335.4	M27	16	766.7	33.45	42	388	163
450	114	67	533	Φ577.9	414	449	356	M30	16	802	41.4	47	445	205
500	127	67	584	Φ635.0	456	467	378	M30	20	842	41.4	50	495	270
600	154	76	692	Φ749.3	549	607	490	M33	20	1161	51	64	597	437
750	167	87	857	Φ914.4	702	697	570	M33	28	1307	60	80	737	741
900	184	92	1108	Φ1085.8	886	794	660	M39	32	1432	60	95	923	1189
1050	222	114	1194	Φ1257.3	1016	1067	737	M39	36	1731	102Dia.*	127	1080	1724
1200	254	130	1359	Φ1422.4	1168	1130	845	M39	44	1953	127Dia.*	140	1200	2117
1350	267	133	1511	Φ1651.0	1329	1248	953	M45	48	2178	152Dia.*	152	1352	2631
1500	292	146	1676	Φ1759.0	1472	1391	1045	M45	52	2423	152Dia.*	165	1500	3175

The above data only for reference, and the detailed parameters in the sample drawing when you make an inquiry.



# SINGLE FLANGE BUTTERFLY VALVE

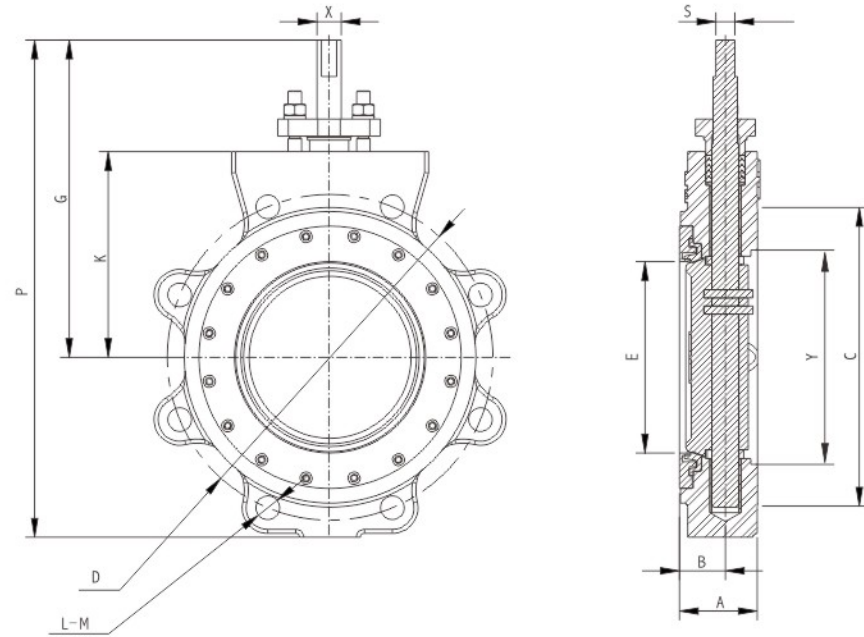

L = Number of Valve Body Bolt Holes  
M = Valve Body Bolt Specification downstream shaft, fire-resistant seat

# SINGLE FLANGE BUTTERFLY VALVE

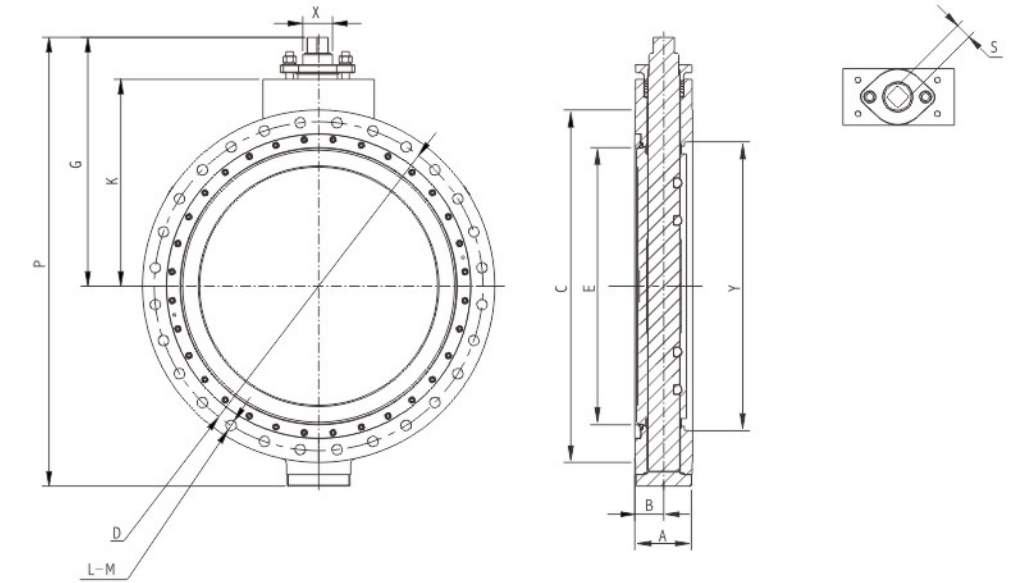

L = Number of Valve Body Bolt Holes  
M = Valve Body Bolt Specification downstream shaft, fire-resistant seat

## 3" ~ 12" (DN 80 ~ 300) Size & Weight

Size		American standard flange 300Lb		National standard flange GB PN40		Japanese standard flange JIS 20K	
NPS	DN	D	L-M	D	L-M	D	L-M
3"	80	Φ168.3	8-M20	Φ160	8-M16	Φ160	8-M20
4"	100	Φ200	8-M20	Φ190	8-M20	Φ185	8-M20
6"	150	Φ269.9	12-M20	Φ250	8-M24	Φ260	12-M22
8"	200	Φ330.2	12-M24	Φ320	12-M27	Φ305	12-M22
10"	250	Φ387.4	16-M27	Φ385	12-M30	Φ380	12-M24
12"	300	Φ450.8	16-M30	Φ450	16-M30	Φ430	16-M24

Size (DN)	Approximate size(mm)													Weight (kg)
	A	B	C	D	E	G	K	M	L	P	S	X	Y*	
80	49	27	132	Φ168.3	73	203	121	M20	8	316	11.2	14.8	89	9
100	54	30	157	Φ200	95	216	133	M20	8	341	11.2	14.8	115	13
150	59	34	216	Φ269.9	142	257	175	M20	12	413	15.9	21.9	159	24
200	73	40	270	Φ330.2	188	306	213	M24	12	495	20.6	28	210	42
250	83	44	324	Φ387.4	236	353	254	M27	16	592	23.8	33.3	254	73
300	92	50	381	Φ450.8	282	389	285	M30	16	675	28.7	37	305	100

The above data only for reference, and the detailed parameters in the sample drawing when you make an inquiry.

## 14" ~ 40" (DN350 ~ 800) Size & Weight

Size		American standard flange 300Lb		National standard flange GB PN40		Japanese standard flange JIS 20K	
NPS	DN	D	L-M	D	L-M	D	L-M
14"	350	Φ514.4	20-M30	Φ510	16-M33	Φ480	16-M30
16"	400	Φ571.5	20-M33	Φ585	16-M36	Φ540	16-M30
18"	450	Φ628.6	24-M33	Φ610	20-M36	Φ605	20-M30
20"	500	Φ685.8	24-M33	Φ670	20-M39	Φ660	20-M30
24"	600	Φ812.8	24-M39	Φ795	20-M45	Φ770	24-M36

Size (DN)	Approximate size(mm)													Weight (kg)
	A	B	C	D	E	G	K	M	L	P	S	X	Y	
350	118	59	413	514	314	417	325	M30	20	730	41.4	50	337	253
400	133	62	470	572	363	440	651	M33	20	781	41.5	50	388	328
450	149	75	533	629	414	542	424	M33	24	960	51	64	445	503
500	162	81	584	686	455	574	447	M33	24	1015	51	64	493	648
600	184	92	692	813	549	634	501	M39	24	1141	60	80	578	984

The above data only for reference, and the detailed parameters in the sample drawing when you make an inquiry.

# DOUBLE FLANGED BUTTERFLY VALVE

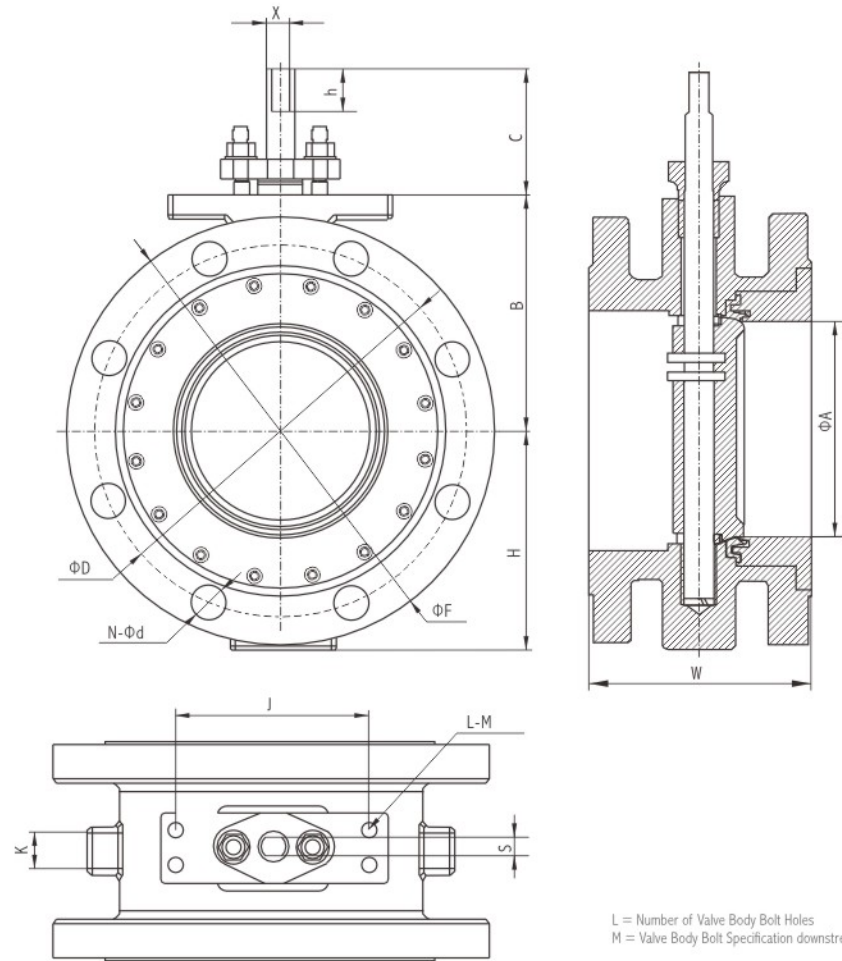

L = Number of Valve Body Bolt Holes  
M = Valve Body Bolt Specification downstream shaft, fire-resistant seat

# DOUBLE FLANGED BUTTERFLY VALVE

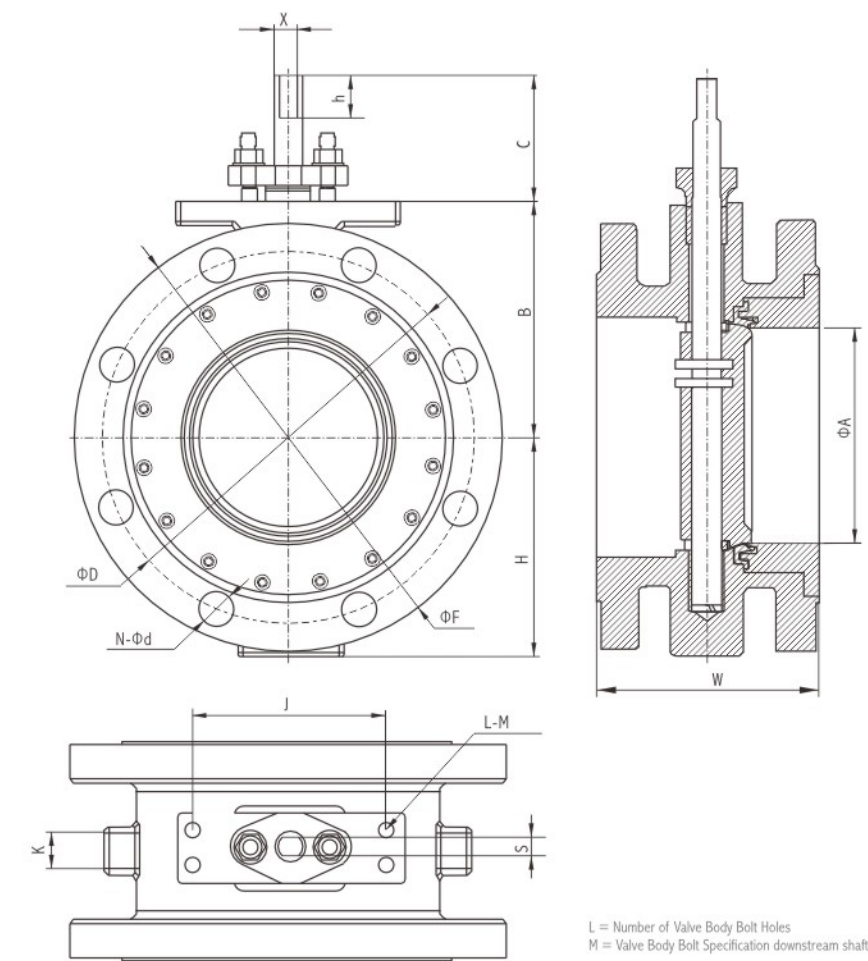

L = Number of Valve Body Bolt Holes  
M = Valve Body Bolt Specification downstream shaft, fire-resistant seat

3" ~ 14" (DN 80 ~ 350) 815D

Size	815D CLASS 150 Approximate size (mm)														
	ΦA	B	H	C	ΦF	W	ΦD	Φd	N	ΦX	S	h	J	K	L-M
3"	73.1	120.7	93.7	82	190	114	152.4	19	4	14.8	11.2	27	125.4	22.4	4-M10
4"	95.6	133.4	110	82	230	127	190.5	19	8	14.8	11.2	27	125.4	22.4	4-M10
5"	111.4	134.9	126.5	82	255	140	215.9	22	8	14.8	11.2	27	125.4	22.4	4-M10
6"	141.7	152.4	143.4	82	280	140	241.3	22	8	18	14	27	125.4	22.4	4-M10
8"	188	187.3	172	82	345	152	298.5	22	8	21.9	15.9	27	125.4	22.4	4-M10
10"	235.9	231.8	202	97	405	165	362	26	12	28	20.6	27	142.8	37.4	4-M12
12"	281.5	260.4	238.1	97	485	178	431.8	26	12	33.3	23.8	33	142.8	37.4	4-M12
14"	315.3	315	294.6	100	535	190	476.3	29	16	37	28.7	41	142.8	37.4	4-M16

The above data only for reference, and the detailed parameters in the sample drawing when you make an inquiry.

16" ~ 60" (DN400 ~ 800)

Size	815D CLASS 150 Approximate size (mm)														
	ΦA	B	H	C	ΦF	W	ΦD	Φd	N	ΦX	S	h	J	K	L-M
16"	362.8	335.3	330	111	595	216	539.8	29	16	42	33.5	41	203.2	82.6	4-M16
18"	413.3	356.2	345	111	635	222	577.9	32	16	47	41.4	41	203.2	82.6	4-M16
20"	454.9	377.1	387	115	700	229	635	32	20	50	41.4	41	203.2	82.6	4-M16
24"	548.8	489.8	474	130	815	267	749.3	35	20	64	51	51	254	107.7	4-M20
28"	682	567	524	157	925	292	863.6	35	28	80	60	51	254	107.7	4-M20
32"	702	570	530	157	985	318	914.4	35	28	80	60	51	254	107.7	4-M20

The above data only for reference, and the detailed parameters in the sample drawing when you make an inquiry.



**With one-stop valve solutions.**

**SHANGHAI ROGERS VALVE CO.,LTD.  
BRAND ROVV HANDA  
ONE-STOP VALVE SOLUTION**

**ADD:**

BUILDING A379,NO.2LANE 158,GANGYEROAD XIAOKUNSHAN TOWN,SONGJIANG DISTRICT,  
SHANGHAI 201616,CHINA

**TEL: +86 1360-6072-028**

**EMAIL: [Janny@rovv-valve.com](mailto:Janny@rovv-valve.com)**

**WEBSITE: [www.rovv-valve.com](http://www.rovv-valve.com)**